

13 Reducing Costs for Ram EDM

Preparing Workpieces for Ram EDM

Since Ram EDM generally machines the entire cavity, it is sometimes cost effective to remove as much material as practical to reduce machining time for workpieces having large cavities.

Difference Between Ram and Wire EDM in Reducing Costs

There is an important difference when ram or wire EDM is used to machine parts. If a blind hex is to be ram EDMed, the hole should be drilled close to the hex as illustrated in Figure 13:1.

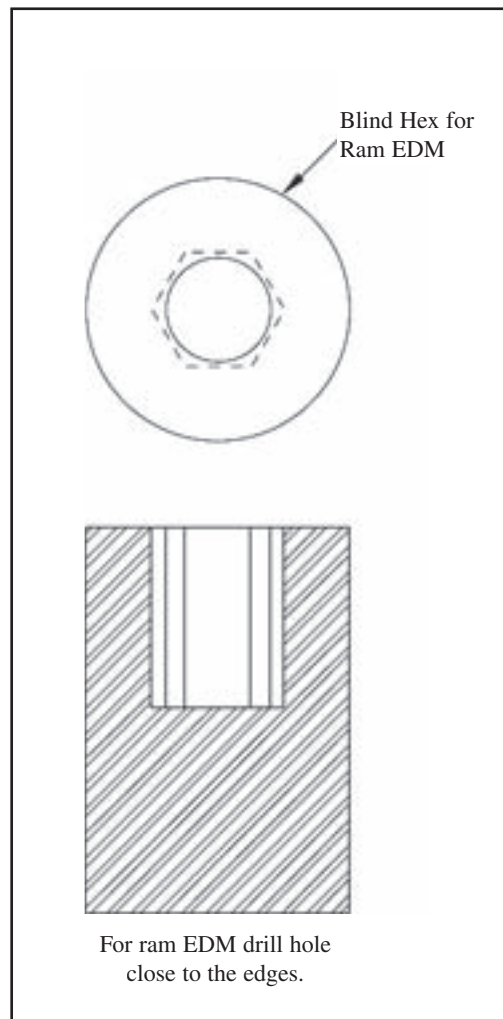

Figure 13:1

Proper Preparation for Ram EDM—Minimal Metal Removal

If a hex goes through the workpiece and wire EDM is used, then just a starter hole should be drilled so as to make one slug. If the hole is drilled to the edge of the hex when wire EDM is used, six slugs will be produced. The wire EDM machine needs to be stopped six times to remove the fallen slugs. Machining one slug will reduce the costs significantly when wire EDM is used. See Figure 13:2.

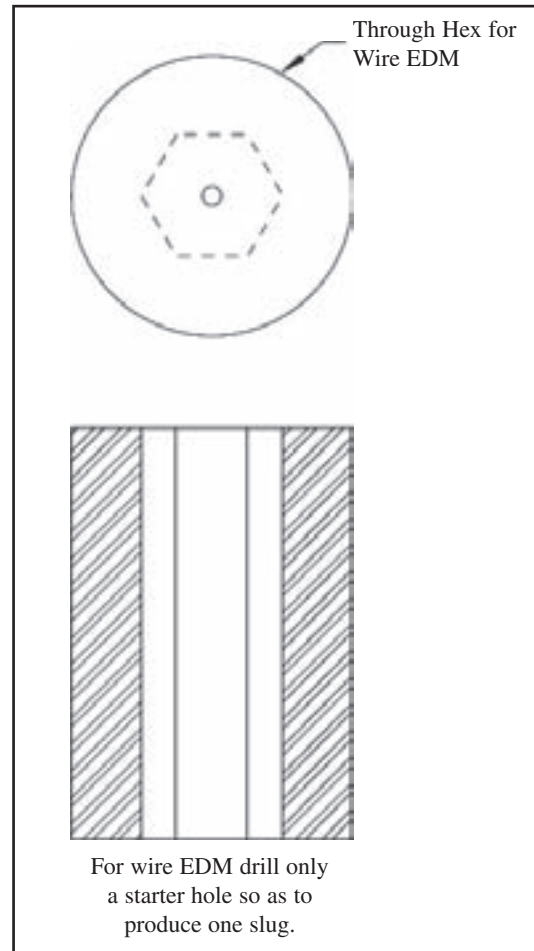

Figure 13:2
Proper Preparation for Wire EDM—Remove One Slug

Prolonging Electrode Life With No-Wear EDMing and No Premachining

Ram EDMing has the capability to cut material with relatively little electrode wear. In previous years, when ram EDM was slow and electrode wear high, roughing out the cavity prior to EDMing was an established practice. Unless the cavity was premachined, costly roughing and finishing electrodes had to be made. Skilled machinists were needed to mill the pocket and to make sure the print was followed. With the advent of solid-state power supplies and premium electrode materials, it became possible to rough out a number of cavities with no-wear settings, even in hardened materials.

Certain cautions need to be applied when using no-wear settings. Premium graphite should be used. (Improper graphite can increase the wear 25%, instead of producing less than 1% wear.) Enough stock should be left for finishing because the gap between the electrode and the workpiece is much greater when roughing than when finishing.

Electrode and Workpiece Holding Devices

Various manufacturers have developed methods that greatly aid ram EDM. There are electrode holders that can be removed from the machine and reinserted into their exact locations. See Figures 13:3 and 4. This reinsert capability is especially important when worn electrodes need to be redressed.

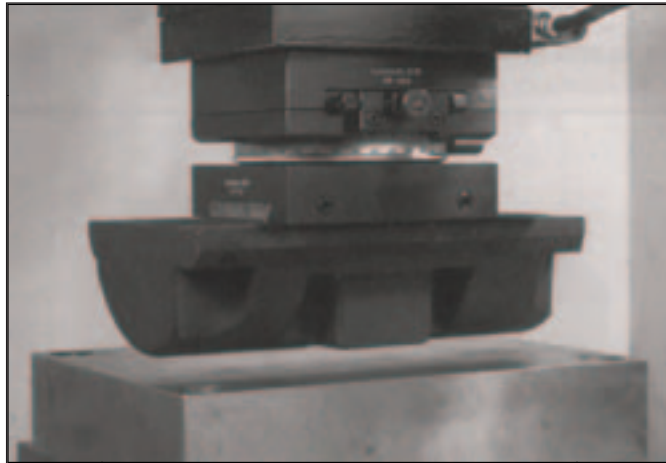

Courtesy System 3R

Figure 13:3

An Electrode Being Held with Special Tooling

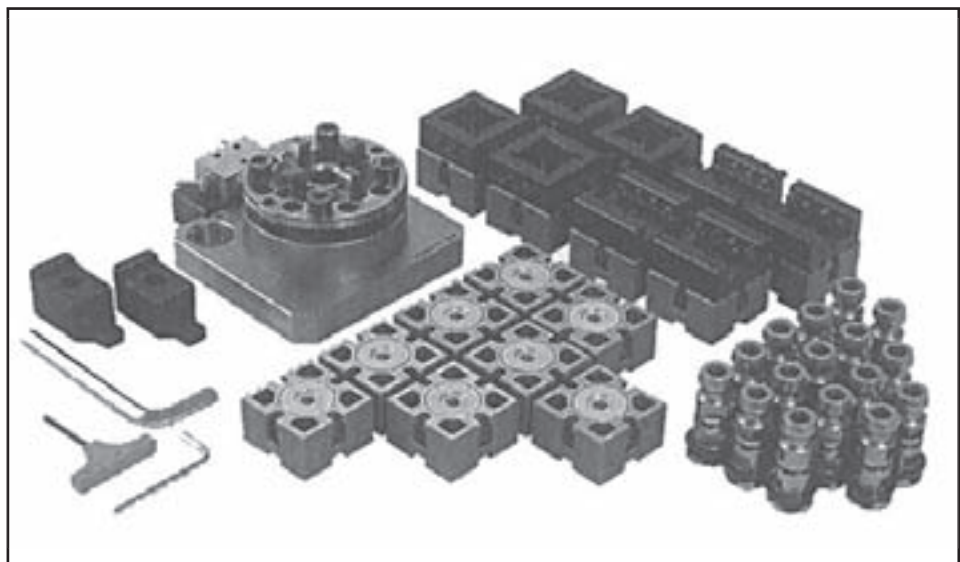

Courtesy System 3R

Figure 13:4

An Electrode Holding Kit

Electrode holders can also be used when machining the electrode. After the electrode is machined, it will be properly oriented because the same holder was used for machining and EDMing.

Palletizing workstations allow workpieces to be placed repeatedly in the required location. Rotating dividing heads allows parts to be rotated and put on an angle for machining, as shown in Figure 13:5.



Courtesy System 3R

Figure 13:5

Dividing Head

Orbiting

One of the most dramatic improvements in ram EDM was the introduction of orbiting. Previously, three to four electrodes were often needed to finish a cavity. A roughing electrode was first used, then two to three finishing electrodes. Unless the electrode could be recut, two or three finishing electrodes were needed because of excessive corner wear, as shown in Figure 13:6. In addition, the finishing electrodes had to be the exact dimension, minus the overcut.

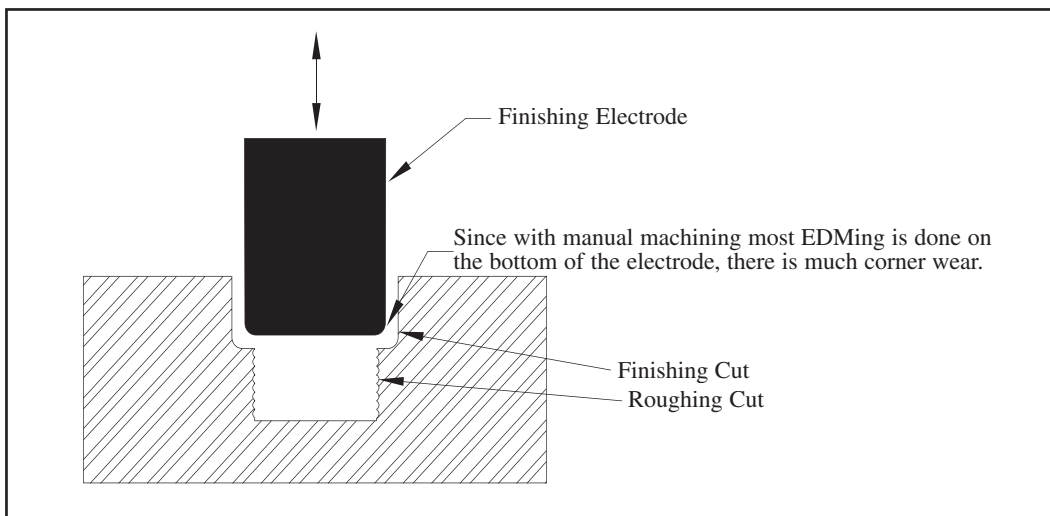

Figure 13:6

Finishing with Manual Machines

With orbiting capabilities, the roughing electrode can often be used for the finishing electrode. This dual use substantially reduces the cost for producing cavities. With an orbiting device, the exact orbit can be set so the cavity will finish to the desired dimension.

The orbital path also aids in the flushing of the cavity by creating a pumping action. Since the same electrode produces the first cavity and the finish cavity, the entire electrode is put into the cavity on the second cut. Now the electrode cuts not only on the bottom, but also along the sides of the electrode. This cutting action greatly reduces corner electrode wear as shown in Figure 13:7.

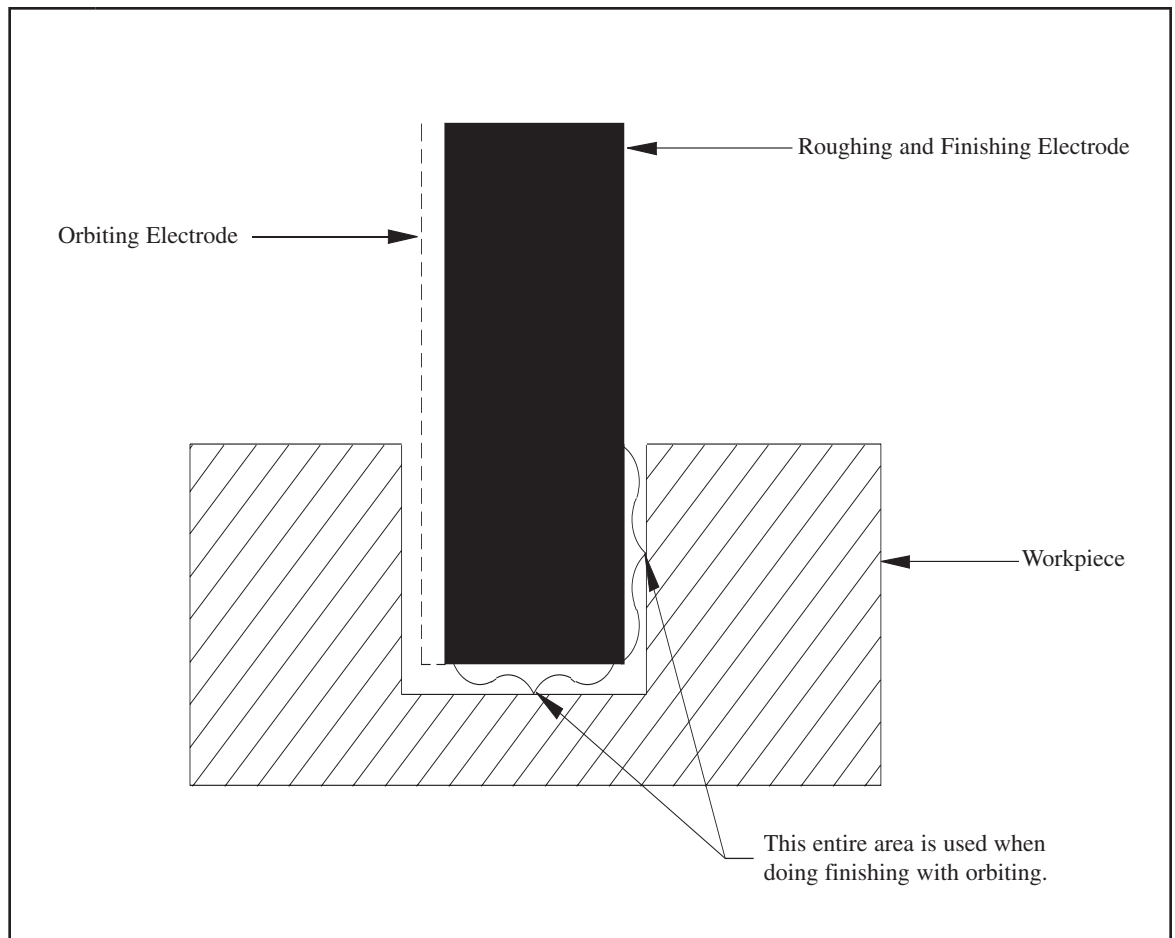
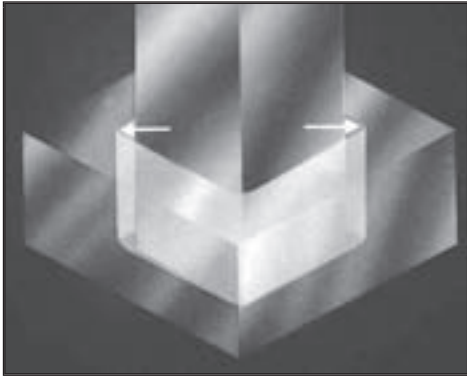

Figure 13:7

Finishing With Orbiting

Since a greater surface area is being machined when orbiting, greater current can be used. Allowing greater current settings increases cutting efficiency without sacrificing surface finish. Orbiting also decreases side wall taper.

Along with CNC came the introduction of various orbital paths, as depicted in Figure 13:8. Such orbital flexibility greatly increased the efficiency of ram EDM cutting.



Down Machining

Cycle on X, Y or Z axis is intended mainly for rough machining.

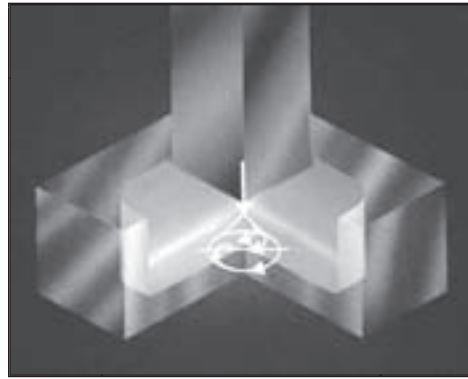

Orbital Machining

Down machining followed by orbits allows machining of three-dimensional forms from roughing to finishing. Machining axis X, Y or Z.

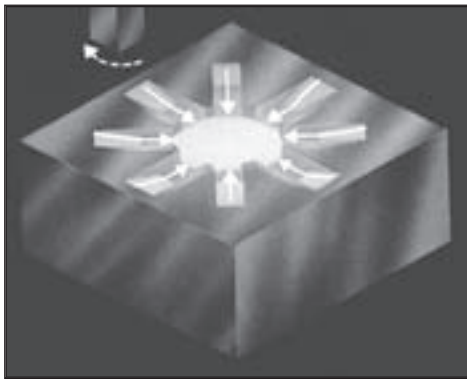

Vectorial Machining

Allows cavity or form machining in any direction.



Vectorial Machining

For servocontrolled machining of the electrode around its axis.

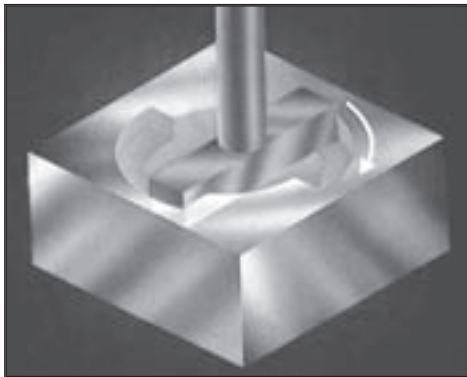

Vectorial Machining

Combined with electrode rotation for machining intricate forms using simple shaped electrodes.



Directional Machining

To obtain sharp corners. Machining axis X, Y or Z. The translation is automatically calculated by the CNC according to the location and the value of the angles to be machined.

Courtesy Charmilles Technologies

Figure 13:8
 Various Orbital Paths

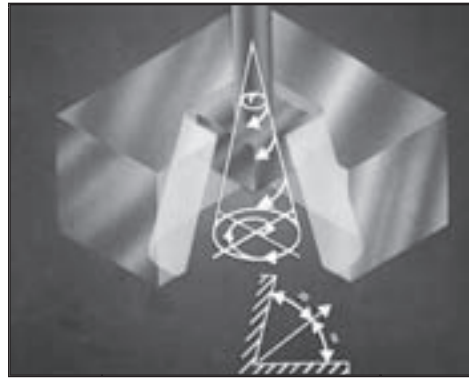

Conical Machining

Of negative and positive tapers encountered, for example, in cutting tools and injection molds. Angles may be programmed from 0° to ± 90°. Machining axis X, Y or Z.

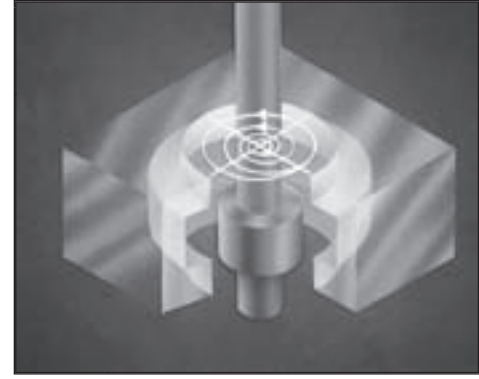

Horizontal Planetary Machining

For grooves, threads, etc. Machining axis X, Y or Z.

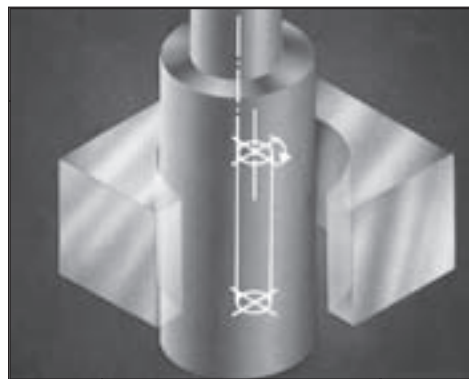

Cylindrical Machining

Permits a non-servocontrolled translation movement of the electrode: for rough machining under poor flushing conditions. Machining axis X, Y or Z.

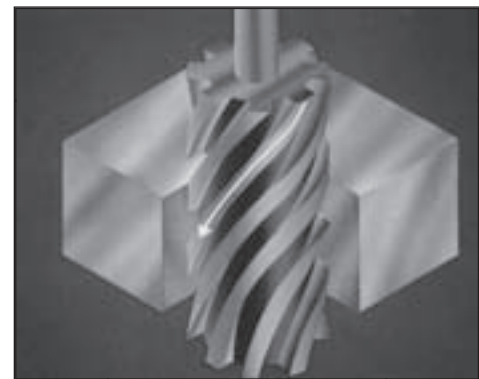

Helical Machining

For threads and helical shapes.

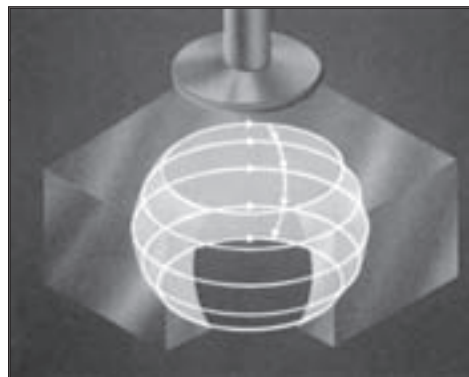

Concave Spherical Machining

Spherical forms can be produced using globe shaped electrodes or spherical caps with thin cylindrical electrodes. Machining axes X, Y or Z.

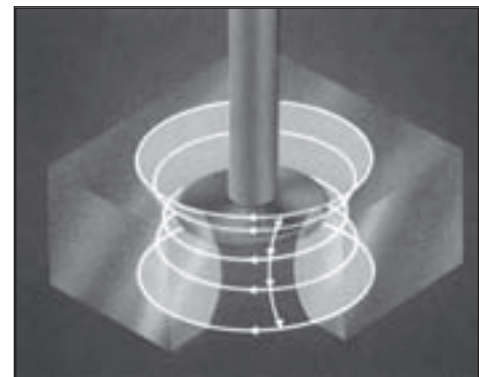

Convex Spherical Machining

Spherical forms can be produced using globe shaped electrodes or spherical caps with thin cylindrical electrodes. Machining axis X, Y or Z.

Courtesy Charmilles Technologies

Figure 13:8

Various Orbital Paths

Manual Machines Mounted With Orbiting Devices

Manual machines can be equipped with orbiting capabilities. These devices are similar to a boring head on a milling machine which allows the electrode to form an orbital path. Although these manual orbiting devices are less sophisticated than CNC orbiting, they increase the cutting efficiency of the manual machines.

Repairing Molds With Microwelding

Traditionally, when nicks, scratches, worn parting lines, or other mold damages were detected, the mold was disassembled and then sent to be TIG (Tungsten Inert Gas) welded. The welder preheated the block to avoid cracking the mold and then welded the defective area. The block was allowed to return to room temperature slowly and then machined and polished. This was a time-consuming process to repair molds, even with minor repairs.

Today, microwelding units that can weld the head of a pin are available. The current discharge is of such short duration and produces such little heat that the smallest repairs can be made without damaging the surrounding area of the mold. Some repairs can be made where the mold remains in the injection molding machine.

A metal strip or wire consisting of material similar to the workpiece is placed over the area. A non-arcing spot welding process bonds the material to the workpiece. After the welding process, the applied material becomes hard. The hardness depends upon what material was used for welding. For small repairs, such as pit marks, a metal paste is used. Since the welds are not excessive, they require less machining and hand polishing. See Figure 13:9.



Courtesy Rocklin Manufacturing

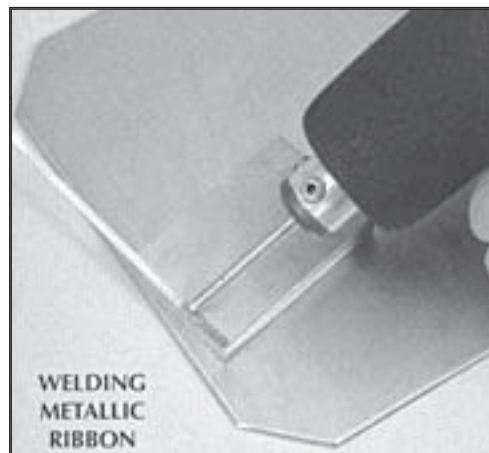

Courtesy Rocklin Manufacturing

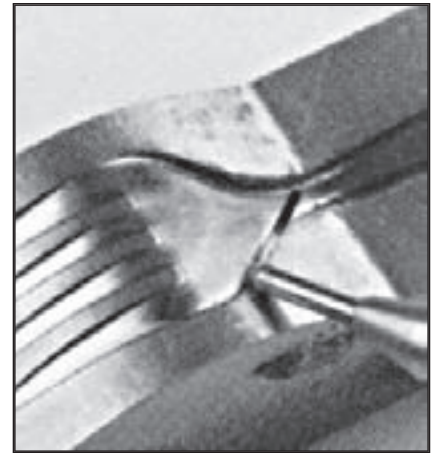

Courtesy Gesswein

Figure 13:9

Rebuilding a Worn Parting Line in a Mold with Microwelding

Abrasive Flow Machining

Some manufacturers use abrasive flow machining to remove the recast layer from EDMing. The process involves two opposing cylinders which extrude an abrasive through the desired surface. The abrasives that are forced over the EDM area polish the surface. Abrasion occurs only in the restricted area.

Automatic Tool Changers

For round-the-clock operation, some companies use automatic tool changers. Units are available that can carry from up to 100 electrodes. These robotic units can change electrodes, as well as workpieces, for unattended operations. Various automatic tool changers are also on the market. See Figure 13:10

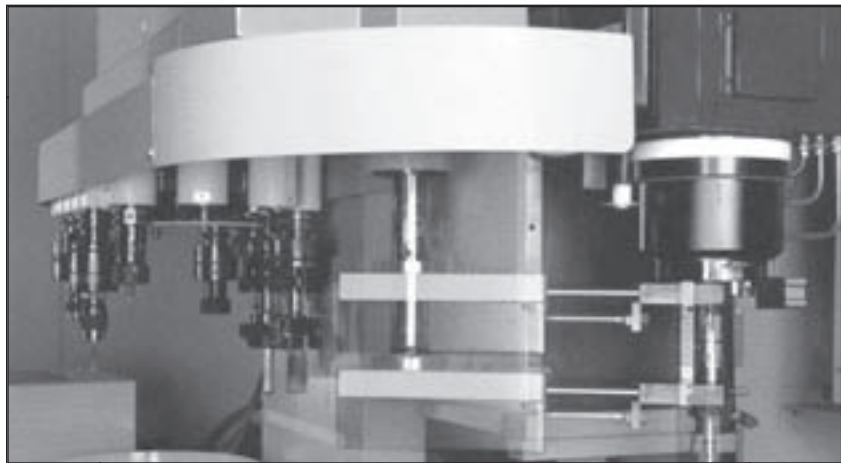

Courtesy Sodick

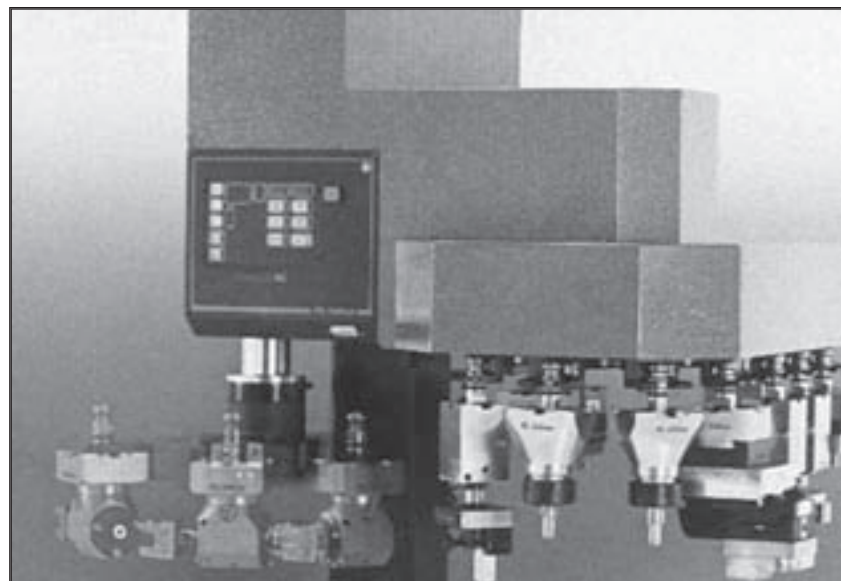

Courtesy Mitsubishi

Figure 13:10

Machines Equipped With Automatic Tool Changers

Automatic changers can also be added to a machine as shown in Figure 13:11.

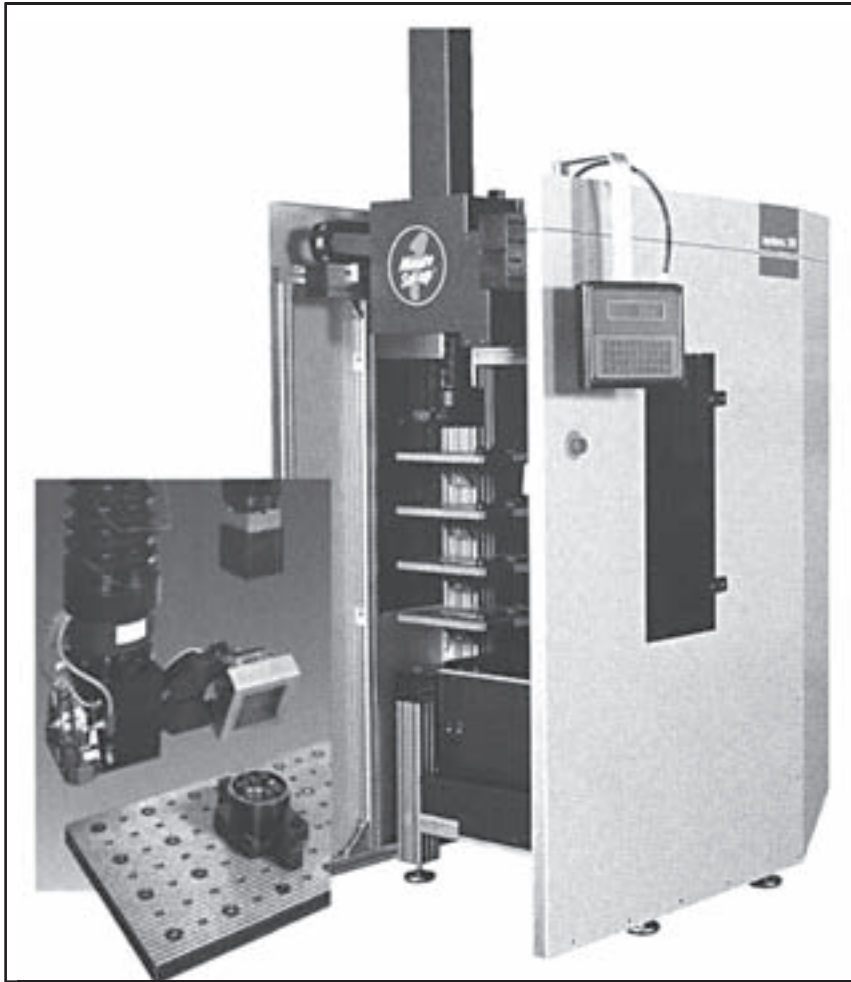

Courtesy System 3R

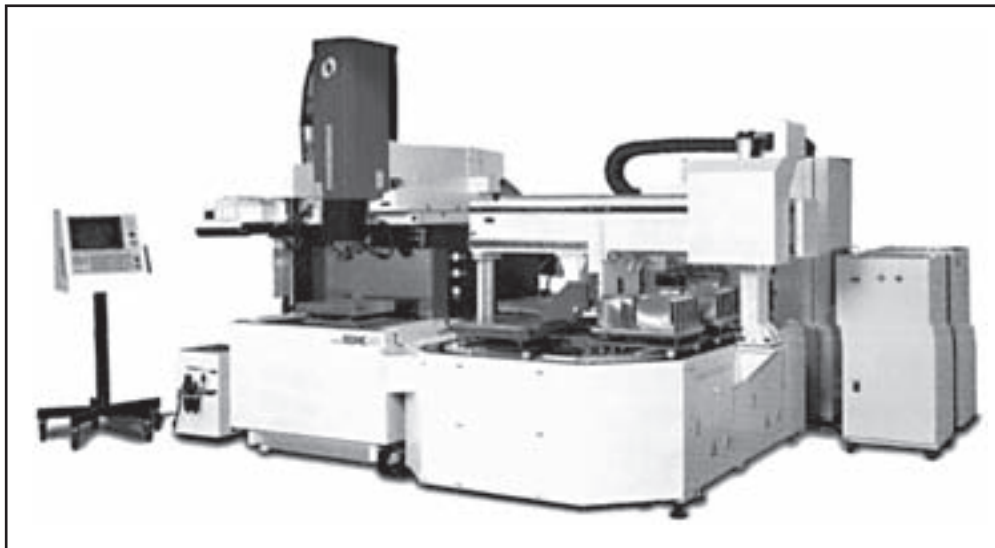

Courtesy Makino

Figure 13:11
Attaching Automatic Changers

Future of Ram EDM

Manufacturers have produced an EDM grinder and an EDM mill, but both projects have been abandoned. However, better power supplies, fuzzy logic, CNC orbiting, and robotic handling of electrodes and workpieces have increased the efficiency of ram EDM. As this process becomes better understood and utilized, it will further reduce machining costs associated with ram EDM.